

GLASS IS LIFE™

O-I makers of pure, sustainable,
brand-building glass packaging

O-I Sales & Distribution Poland LLC

ul. Morawska 1
37-500 Jaroslaw, Poland
Tel. +48 166249200

**CONTAINER & MOULD ENGINEERING
EUROPE**

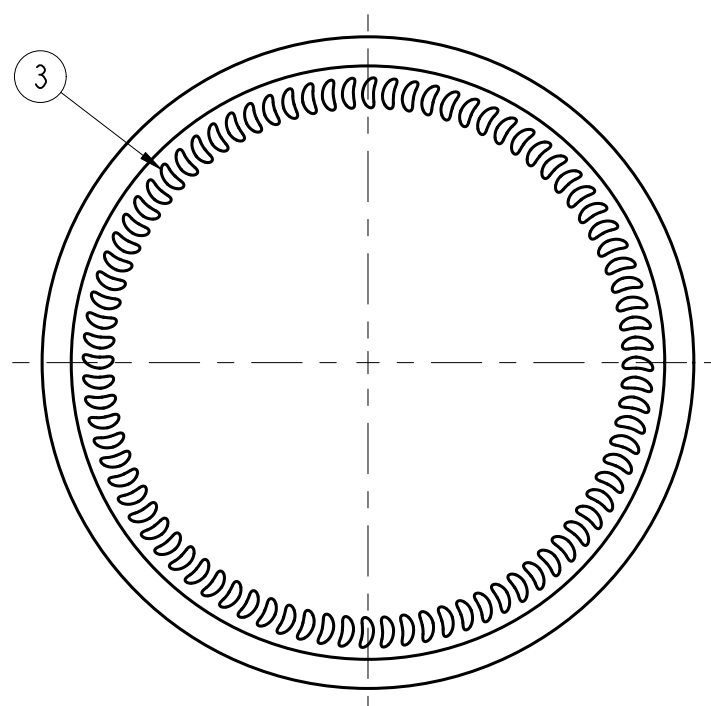
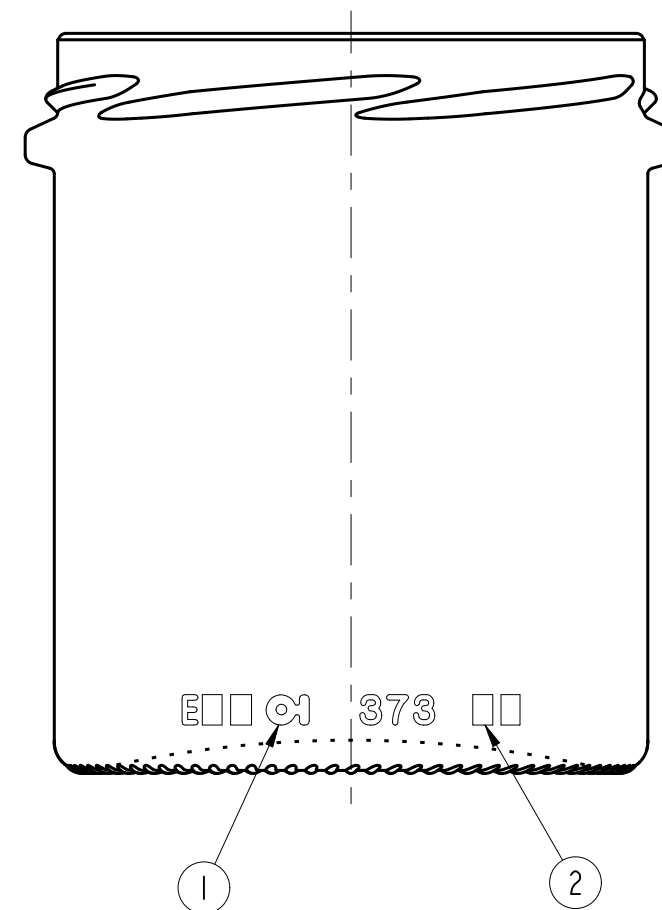
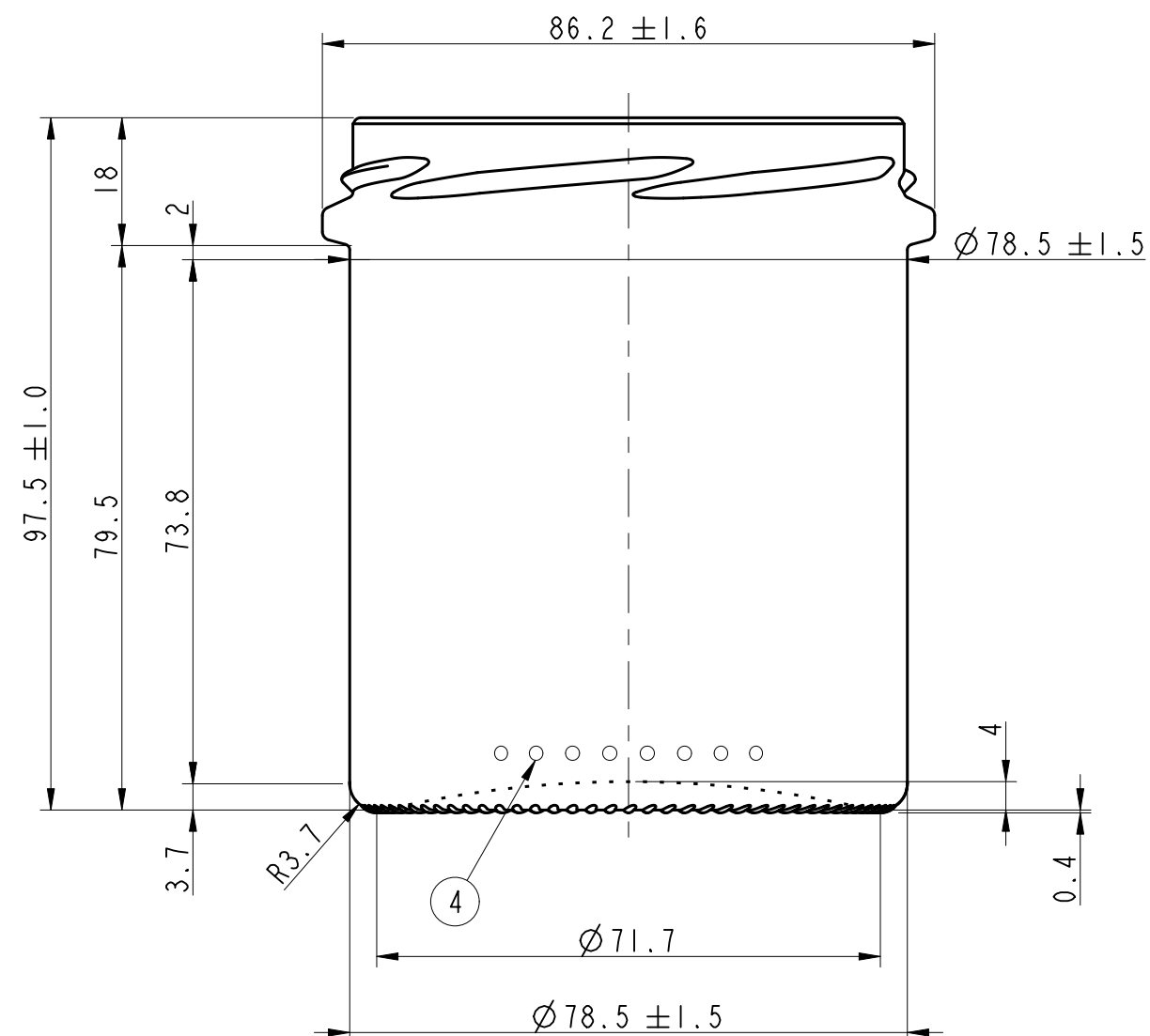

NOTES:
THIS DRAWING IS THE PROPERTY OF O-I AND
MUST NOT BE REPRODUCED OR DISCLOSED
WITHOUT O-I WRITTEN AUTHORIZATION.

DIMENSIONS EXPRESSED IN mm
ONLY TOLERANCED DIMENSIONS ARE GUARANTEED.

MANUFACTURING MARKINGS SHOWN ARE FOR ILLUSTRATIVE
PURPOSES ONLY, ACTUAL MARKINGS ON CONTAINER
MAY DIFFER, DEPENDANT ON LOCAL LEGISLATION.

CATEGORY FOOD		TILT ANGLE 37.51°	
MAX. VERTICALITY TOLERANCE		MEASURING CONTAINER NO	
FINISH SAP NUMBER 7684		FINISH REF. SPECIAL	
MINIMUM THROUGH BORE		MAX FILLING TUBE Ø	
CONTAINER OVERFLOW CAPACITY (BRIMFUL)			
373ml ± 10, 4ml			
CONTAINER RATED CAPACITY (FILLPOINT)			
-			
CONTAINER WEIGHT			
229g APPROX.			
FINISH DESIGNATION PL_82_SPECIAL_H180_7684		MAX GAS VOLUME	
PROCESS PB	RETURNABLE NO	DESIGN REF. Eu 22415 / z7684	
Standard 373ml TO			
DESIGNER	BK	DATE	15/02/17
CHECKED	SH	DATE	15/02/17
DRAWING NUMBER 170024		MOULD/SAP NUMBER 170024	

1 = TRADEMARK
2 = CAVITY No.
3 = STIPPLING
THE SHAPE OF STIPPLES IS ONLY AN
INDICATION AND THE CONSTRUCTION IS AT
THE PRODUCTION PLANT DISCRETION.
4 = CAVITY CODE

SCALE 1:1

3	19/10/17	name, main diameter [was Ø78.2], brimful capacity	BK/SH
2	12/10/17	name, main diameter [was Ø77.0], brimful capacity	BK/SH
1	06/06/17	Changed overflow capacity. [was 346ml]	NP/SH
	02/03/17	APPROVED VERSION 02	BK/SH
No	DATE	REVISIONS	DESIGN/CHECK