

GLASS IS LIFE™

O-I makers of pure, sustainable,
brand-building glass packaging

O-I Sales & Distribution Poland LLC

ul. Morawska 1
37-500 Jaroslaw, Poland
Tel. +48 166249200

CONTAINER & MOULD ENGINEERING EUROPE

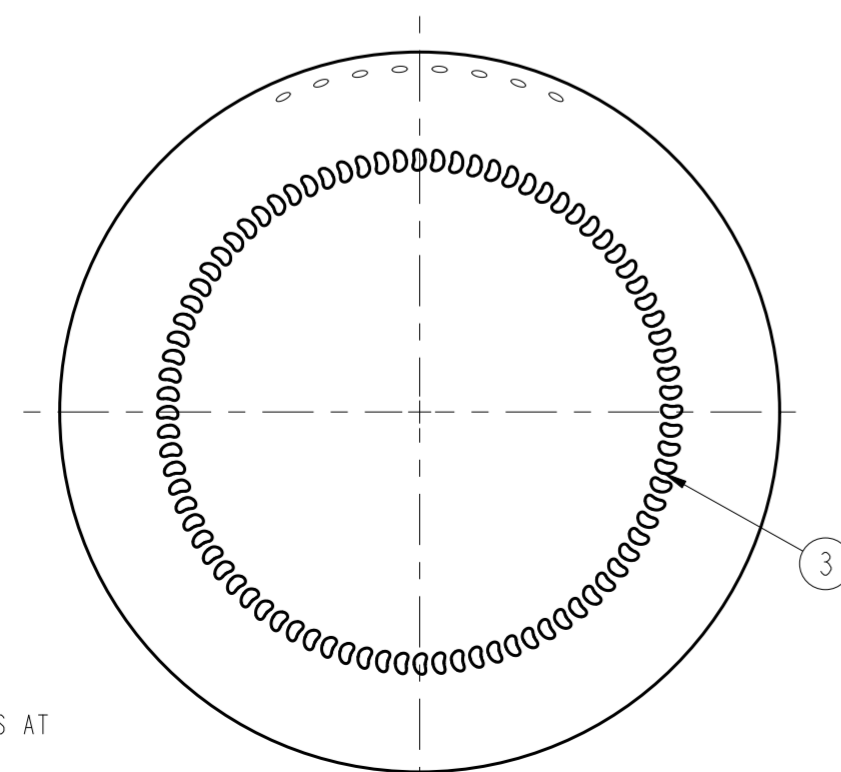
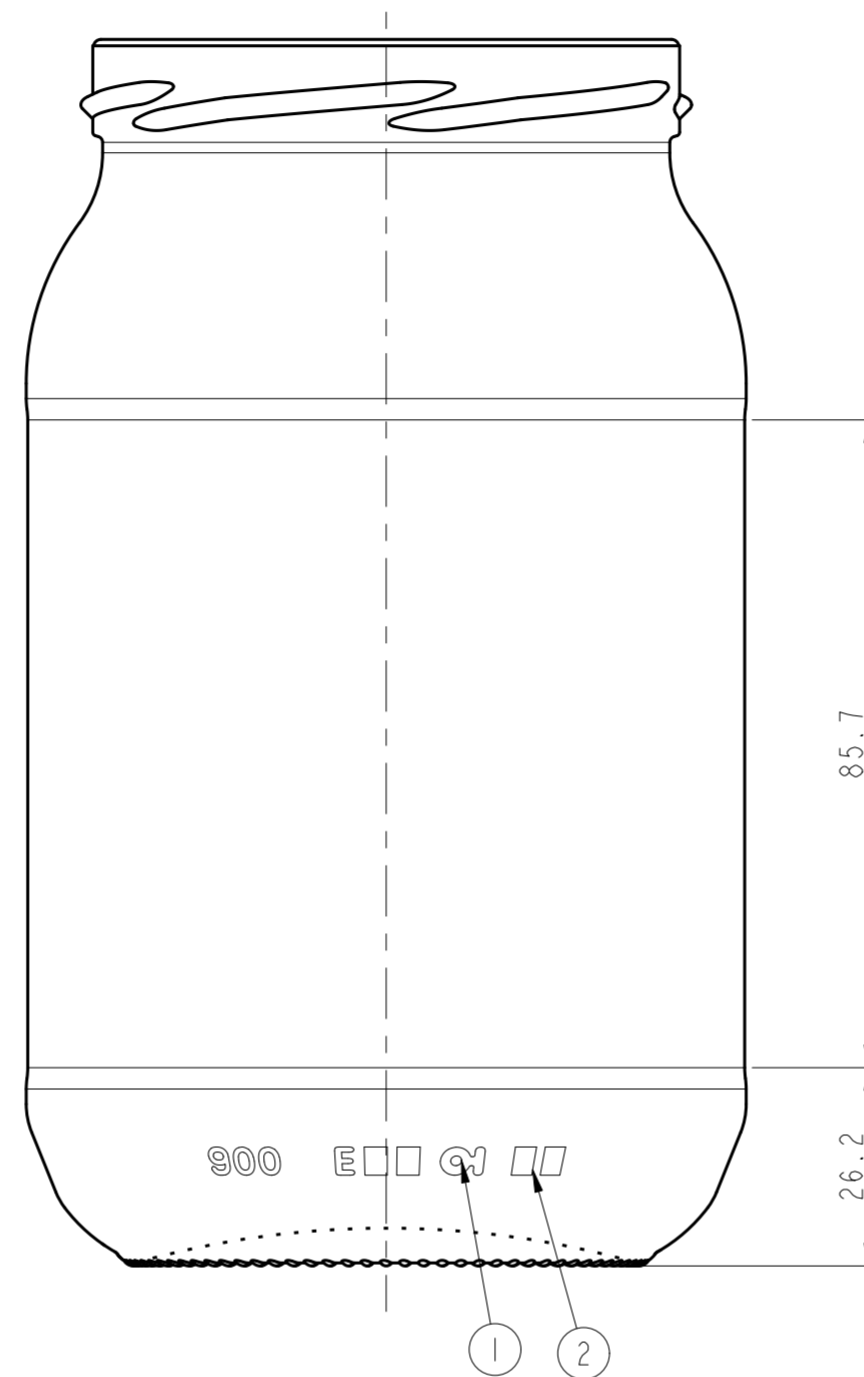
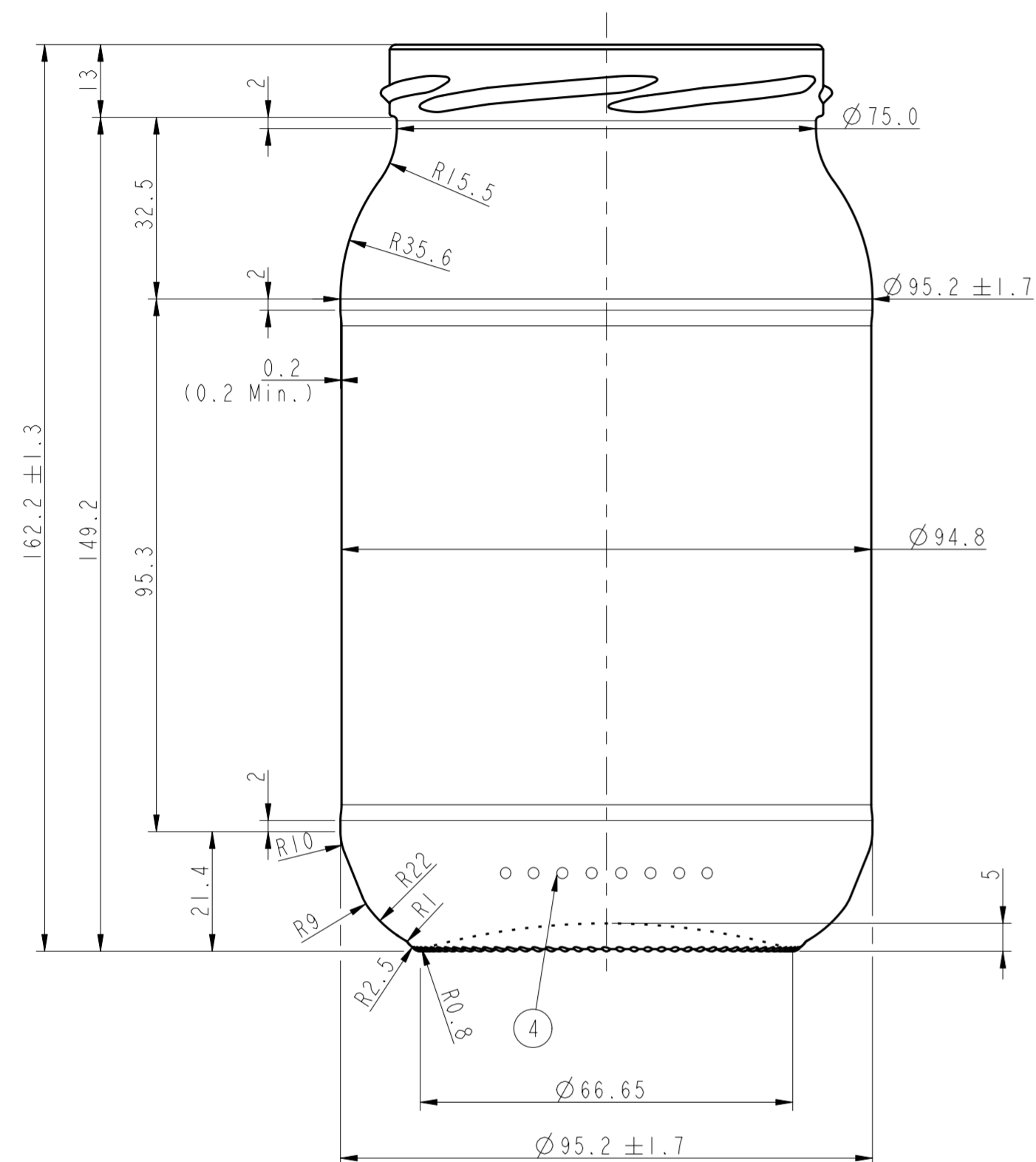

1 = TRADEMARK
2 = CAVITY No.
3 = STIPPLING
THE SHAPE OF STIPPLES IS ONLY AN INDICATION AND THE CONSTRUCTION IS AT THE PRODUCTION PLANT DISCRETION.
4 = CAVITY CODE

SCALE 1:1

NOTES:
THIS DRAWING IS THE PROPERTY OF O-I AND MUST NOT BE REPRODUCED OR DISCLOSED WITHOUT O-I WRITTEN AUTHORIZATION.

DIMENSIONS EXPRESSED IN mm
ONLY TOLERANCED DIMENSIONS ARE GUARANTEED.

MANUFACTURING MARKINGS SHOWN ARE FOR ILLUSTRATIVE PURPOSES ONLY, ACTUAL MARKINGS ON CONTAINER MAY DIFFER, DEPENDANT ON LOCAL LEGISLATION.

CATEGORY FOOD		TILT ANGLE 23.57°	
MAX. VERTICALITY TOLERANCE		MEASURING CONTAINER NO	
FINISH SAP NUMBER 4976		FINISH REF. CETIE GME 20-09 1995	
MINIMUM THROUGH BORE		MAX FILLING TUBE Ø	
CONTAINER OVERFLOW CAPACITY (BRIMFUL)			
900ml ± 10ml			
CONTAINER RATED CAPACITY (FILLPOINT)			
CONTAINER WEIGHT			
335g APPROX.			
FINISH DESIGNATION EU_82_GME 20-09_H130_4976		MAX GAS VOLUME	
PROCESS PB	RETURNABLE NO	DESIGN REF.	
90cl GOLIA 2			
DESIGNER	NP	DATE	20/01/16
CHECKED	SH	DATE	20/01/06
DRAWING NUMBER 160031		MOULD/SAP NUMBER 160031	

No	DATE	REVISIONS	DESIGN/CHECK
1	05.12.2016	Changed total weight (was 330g)	NP/SH
	11.02.2016	Approved version 01	NP/SH