

O-I Manufacturing Poland S.A.
 ul. Morawska 1
 37-500 Jaroslaw, Poland
 Tel. +48 166249200

CONTAINER & MOULD ENGINEERING
EUROPE

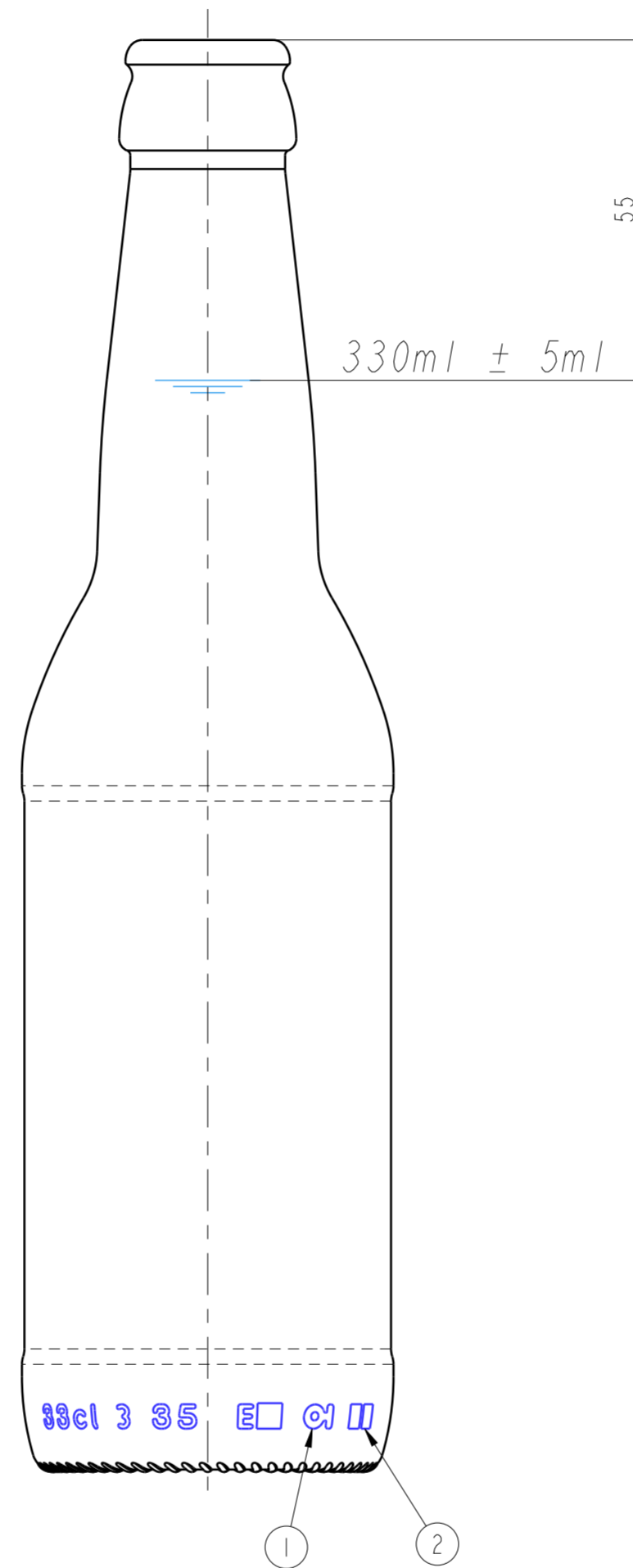
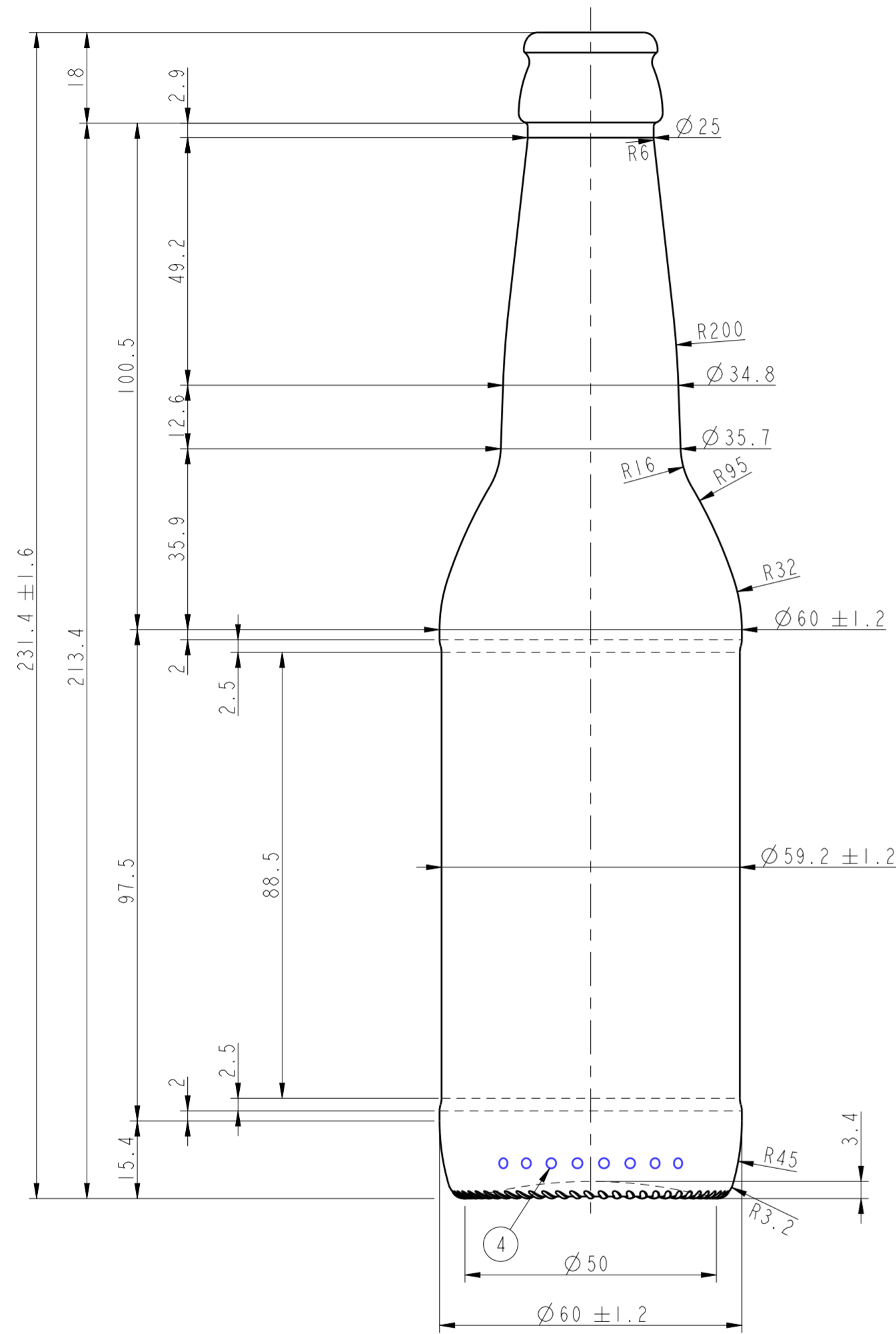

NOTES:
 THIS DRAWING IS THE PROPERTY OF O-I AND
 MUST NOT BE REPRODUCED OR DISCLOSED
 WITHOUT O-I WRITTEN AUTHORIZATION.

ONLY TOLERANCED DIMENSIONS ARE GUARANTEED.

MANUFACTURING MARKINGS SHOWN ARE FOR ILLUSTRATIVE
 PURPOSES ONLY, ACTUAL MARKINGS ON CONTAINER
 MAY DIFFER, DEPENDANT ON LOCAL LEGISLATION.

1 = TRADEMARK
 2 = CAVITY No.
 3 = STIPPLING
 THE SHAPE OF STIPPLES IS ONLY AN
 INDICATION AND THE CONSTRUCTION IS AT
 THE PRODUCTION PLANT DISCRETION.
 4 = CAVITY CODE

SCALE 1:1

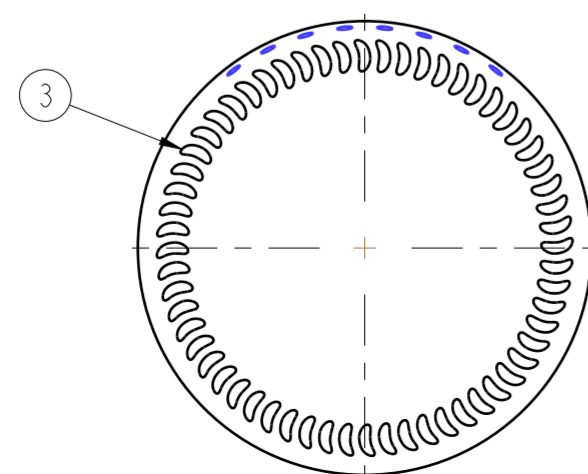

CATEGORY NAB		TILT ANGLE 16.83°	
MAX. VERTICALITY TOLERANCE		MEASURING CONTAINER YES	
FINISH SAP NUMBER 0612		FINISH REF. SPECIAL	
MINIMUM THROUGH BORE		MAX FILLING TUBE Ø	
CONTAINER OVERFLOW CAPACITY (BRIMFUL)			
350ml APPROX.			
CONTAINER RATED CAPACITY (FILLPOINT)			
330ml ± 5ml			
CONTAINER WEIGHT			
204g APPROX.			
FINISH DESIGNATION PL_26_SPECIAL_H180_0612		MAX GAS VOLUME	
PROCESS NNPB	RETURNABLE NO	DESIGN REF. EU3824/z021B/5708	
33cl JW I			
DESIGNER	TP	DATE	12.03.2010
CHECKED	SH	DATE	12.03.2010
DRAWING NUMBER 100240		MOULD/SAP NUMBER 100240	

No	DATE	REVISIONS	DESIGN/CHECK